

DIP Switches

DIP Switch Half Pitch SMT for Highest Reliability

DX62 Series

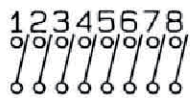
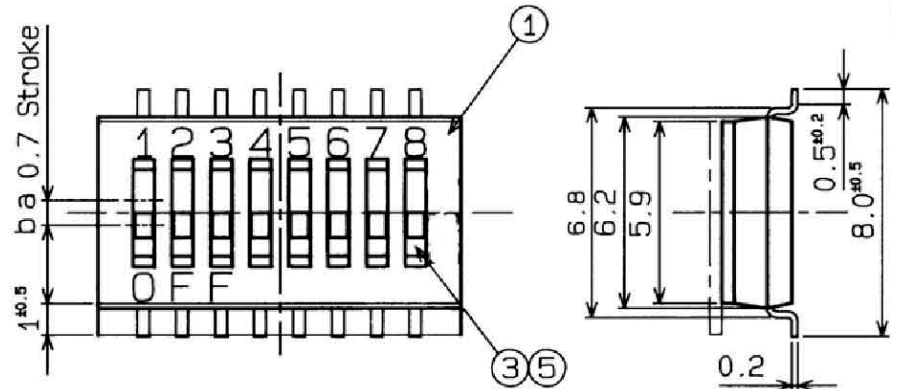
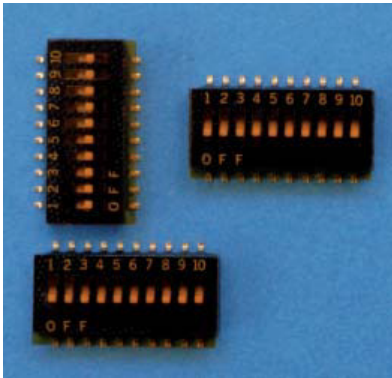

ex) 8 poles circuit of position b

UNIT: mm

10	14.43	11.43
08	11.89	8.89
06	9.35	6.35
04	6.81	3.81
PO	Dim.A	Dim.B

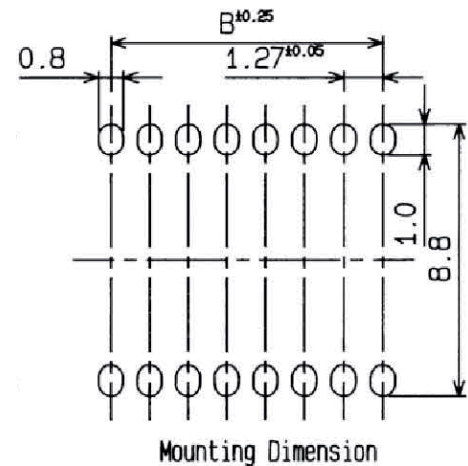
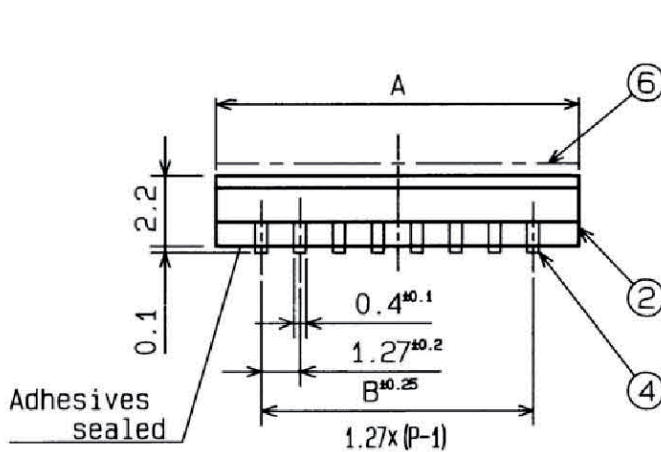

How to order:

DX62 RoHS Compliant

1 NO. OF POSITIONS:

- 04 4 Positions
- 06 6 Positions
- 08 8 Positions
- 10 10 Positions

2 TAPE SEALING:

- T Top Tape Sealed (Standard)
- no code Without Top Tape

3 PACKAGE STYLE:

- TR Tape and Reel

Material:

	Part Name	Material	quantity	Treatment
1	Cover	P. P. S.	1	Black Color
2	Base	P. P. S.	1	Black Color
3	Slide	Polyamide	1xPole	Yellow Color
4	Terminal	Copper Alloy	2xPole	Gold over Nickel (0.2µmAu average)
5	Moving Contact	BeCu Alloy	1xPole	Gold over Nickel (0.2µmAu average)
6	Tape	Polyimide	1	
GENERAL TOLERANCE:				+/- 0.3 mm

- * The switch is 100% machine inspection.
- * The plating process is electrolytic plating.

Specifications

1. General Specifications

1-1. Applications

This specifications shall be applied to switch for low voltage circuit (secondary circuit) engaged in electronic equipments.

1-2. Temperature Range for specifications

- (a) For operation ; -20~+80℃
- (b) For storage ; -55~+85℃

1-3. Test conditions

Unless noticed in this specifications, tests shall be made under the conditions of temperature 5~35℃, relative humidity 45~85% and atmospheric pressure 86~106 Kpa.

But especially requested, they shall be made under the conditions of temperature $20 \pm 2^\circ\text{C}$, relative humidity $65 \pm 5\%$ and atmospheric pressure 86 ~ 106 kpa.

2. Appearance and structure

2-1. Appearance

Stain, crack, and damaged plating which will be harmful for its functions shall not be found in appearance.

2-2. Structure

Structure and dimension are described in the attached drawing sheet.

2-3. Materials and Treatment

According to the attached drawing sheet.

2-4. Rating

- (a) Non-shorting ; D.C. 50V 100 μ A~0.1A
- (b) Switching ; D.C. 6V 100 μ A~0.1A
; D.C. 24V 100 μ A~0.025A

3. Electrical Performance

	Item	Test Condition	Effect
3-1	Contact Resistance	Measured by micro ampere-meter.	Max. 100 m Ω
3-2	Insulation Resistance	At D.C. 100V between adjacent and opposite terminals.	Min. 100 M Ω
3-3	Breakdown Voltage	At A.C. 250V(Leak current 1mA) for 1 minute between adjacent and opposite terminals.	No insulation breakage
3-4	Capacitance	At 1000 KHz between adjacent and opposite terminals.	Max. 5 pF

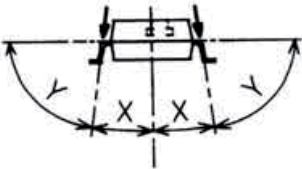
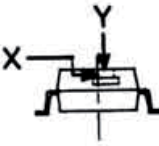
4. Mechanical Performance			
	Item	Test Condition	Effect
4-1	Operation Force	Measured at the tip of slider by Tension Gauge.	Max. 4 N(400 gf)
4-2	Terminal Strength	<p>Static 5 N load for 1 minute to the direction of following arrows. 1 time to 1 terminal. Bending shall be 1 time to X and Y direction within 30° .</p> 	<p>No damage shall be found in terminals and switch base.</p> <p>Electrical Performance Section 3 shall be kept.</p>
4-3	Slider Strength	<p>Gradual 5 N load to X and Y directions of slider for 15 sec. by Tension Gauge as described below</p> 	<p>No damage shall be found in sliders.</p> <p>No mechanical trouble shall be caused.</p>
4-4	Vibration	<p>MIL-STD-202F-201A After fixed to test equipment, following conditions shall be tested;</p> <p>(1) Range ; 10~55 Hz (2) Amplitude; 1.5mm (3) Ratio ; 10~55~10 Hz for 1 minute (4) Changing ; Logarithm or approximation of straight line (5) Direction; 3 vertical direction (6) Time ; 2 hours for each (total 6 hours)</p>	<p>Contact Resistance; (Section 3-1) Max. 100mΩ.</p> <p>Insulation Resistance; (Section 3-2) Min. 100 MΩ.</p> <p>Breakdown Voltage ; (Section 3-3) No insulation breakage.</p> <p>Operation Force ; Max. 4 N(400gf)</p>

4. Mechanical Performance												
	Item	Test Condition	Effect									
4-5	Shock	<p>MIL-STD-202F-213B</p> <p>After fixed to test equipment. following conditions shall be tested;</p> <p>(1) Acceleration ; 50 G</p> <p>(2) Operation Time ; 11m sec.</p> <p>(3) Direction ; 6 faces</p> <p>(4) Times ; 3 times to each direction (total 18 times)</p>	<p>Ellectrical Performance</p> <p>Section 3-1~3-3 shall be kept.</p> <p>Operation Force; Max. 4 N(400 gf)</p> <p>No damage in appearance and structure.</p>									
4-6	Solderablity	<p>(1) Solder; H 63A</p> <p>(2) Flux ; Isopropyl alcohol solution of rosin line, of which weight ratio is 30%.</p> <p>(3) Solder Temperature and steeped time; 250± 5℃, 10± 0.5 sec. Steeped time of flux shall be 5~10 sec.</p> <p>(4) Depth ; After mounted on. solder shall steep P.C.B. (t=1.6) up to the surface covered with copper-foil.</p>	<p>More than 75% shall be covered with steeped solder.</p>									
4-7	Resistance to Soldering Heat	<p>(1) Solder ; H 63A</p> <p>(2) Flux ; Isopropyl alcohol solution of rosin line, of which weight ratio weight ratio is 30%</p> <p>(3) Temperature and time ;</p> <table border="0"> <tr> <td></td> <td>Temp. (℃)</td> <td>Time. (sec)</td> </tr> <tr> <td>Manual;</td> <td>320± 10</td> <td>Within 3</td> </tr> <tr> <td>other;</td> <td>250± 5</td> <td>Within 10</td> </tr> </table> <p>(for Vapor Phase Reflow Soldering)</p>		Temp. (℃)	Time. (sec)	Manual;	320± 10	Within 3	other;	250± 5	Within 10	<p>No damage in appearance and operation. section 3 shall be kept</p> <p>* No load to terminals at soldering.</p> <p>* Flux should not steep inside of switch at soldering.</p>
	Temp. (℃)	Time. (sec)										
Manual;	320± 10	Within 3										
other;	250± 5	Within 10										

4. Mechanical Performance			
	Item	Test Condition	Effect
4-8	Washing: Applied only to sealed tape type.	(1) Solution 1-1-1 Trichloroethane, Freon TE or solution of isopropyl alcohol line (2) Washing For 2 minutes by ultra-sonic wave (28 KHz) * Please wash switch in room temperature after soldering. (after 30 minutes in room temperature or after cooling down by Fan)	Electrical Performance Section 3-1~3-3 shall be kept. Operation Force; Max. 4 N(400 gf) No damage in appearance and structure.
5. Durability			
5-1	Mechanical Life	Continuously 1000 cycles at no load. (Operation speed 20~25 cycles per minute)	Electrical Performance Section 3-1, 3-3 shall be kept. Insulation Resistance; Min. 10MΩ Operation Force; Max. 4 N(400 gf) No damage in appearance and structure.
5-2	Electrical Life	Continuously 1000 cycles at D.C. 24V with 0.025A. (resistive load) (Operation speed 20~25 cycles per minute)	Electrical Performance Section 3-1, 3-3 shall be kept. Insulation Resistance; Min. 10MΩ Operation Force; Max. 4 N(400 gf) No damage in appearance and structure.

SPECIFICATIONS OF CARRYING TAPE

1. Applications

This specifications shall be applied to carrying tape for the series, which includes 4 models, here in after referred to 4P, 6P, 8P, 10P.

This specifications is based on the regulations of JIS C0806 and EIAJ RC-1009A for S.M.D. carrying tape.

2. Dimension and Structure

2-1. Dimension

Mentioned in the attached drawing sheet.

2-2. Structure

Carrying tape is constituted of embossed tape and sealed tape which is stucked to on the embossed tape. (Figure 1)

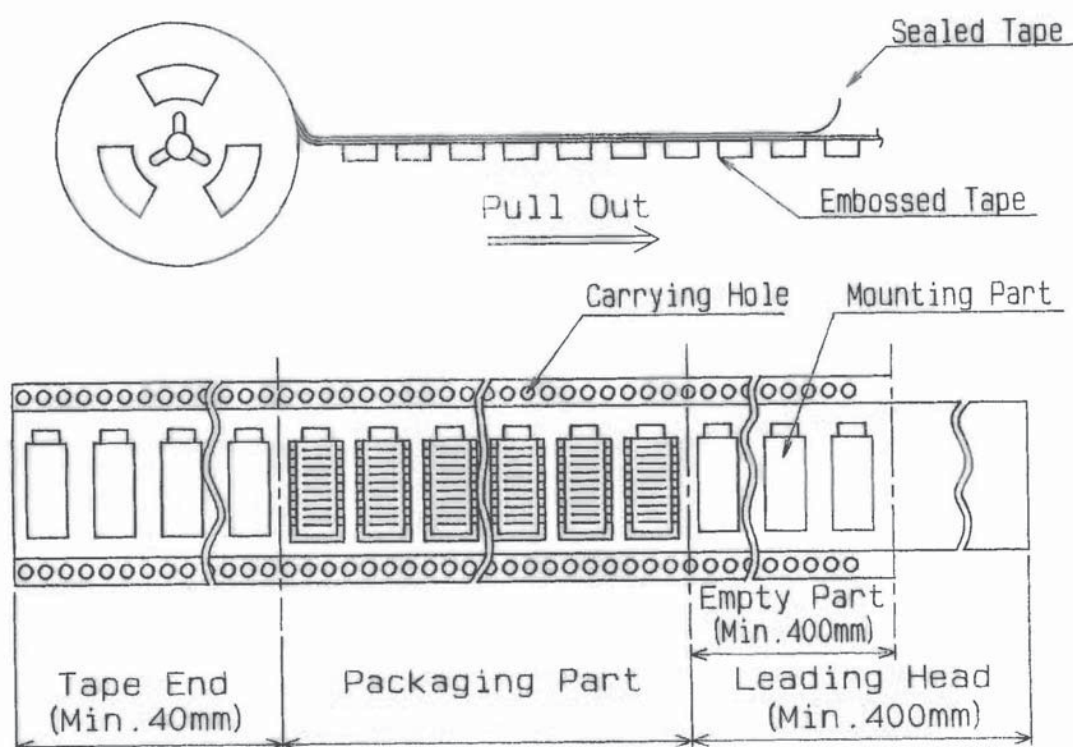

Figure 1: Carrying Tape (in the case of 10p)

2-3. Position of Carrying Hole

To the direction of pulling out carrying tape,

- (a) carrying hole is set at left side in the tape of 4P, 6P, 8P.
- (b) carrying hole is set at both sides in the tape of 10P.

2-4. Leading Head

Leading Head shall include more than 20 pitches, of which length shall be more than 400mm. These pitches of embossed tape are sealed with sealed tape.

2-5. Tape End

Tape End shall include empty part of embossed tape, of which length shall be more than 40mm.

2-6. Fixture of Tape End

Tape end shall be fixed to reel core by adhesive tape. (Figure 2)

3. Fixture of Leading Head

Leading head shall be fixed by adhesive tape. (Figure 3)

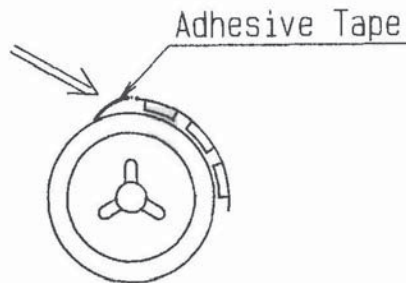

Figure 2: Fixture of Tape End

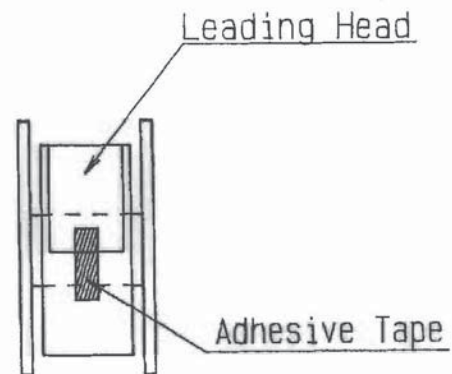

Figure 3: Fixture of Leading Head

4. Mechanical Characteristics of Carrying Tape

4-1. Detachment Force of sealed tape

Unless noticed in this specification, detachment force shall be 0.1 ~ 0.7N (10.2 ~ 71.4 gf) at the detachment angle 165 ~ 180° by 300mm per minute. (Figure 5)

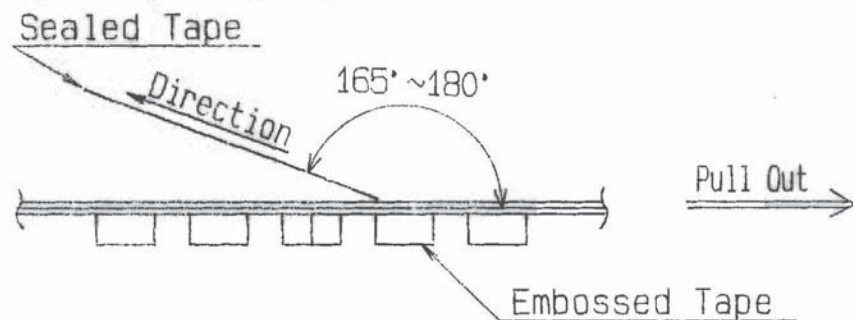

Figure 5: Detachment of Sealed Tape

5. Ather

(1) Storage for Reel Package

Storage shall be made under the conditions of -5 ~ +40 °C and relative humidity 40 ~ 60% without direct rays of the sun.

(2) Direction of parts

No.1 pole shall be right side of drawing direction as shown below figure 6.

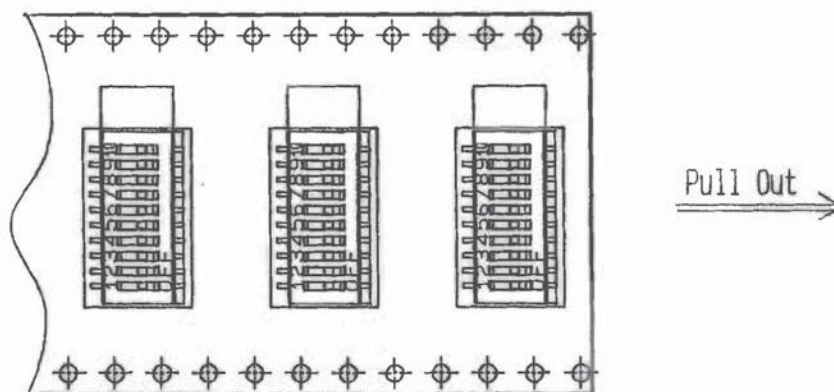
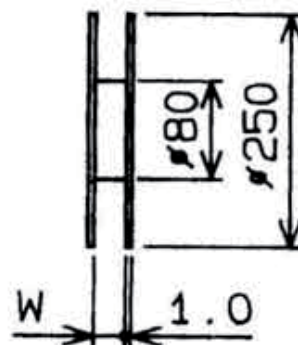
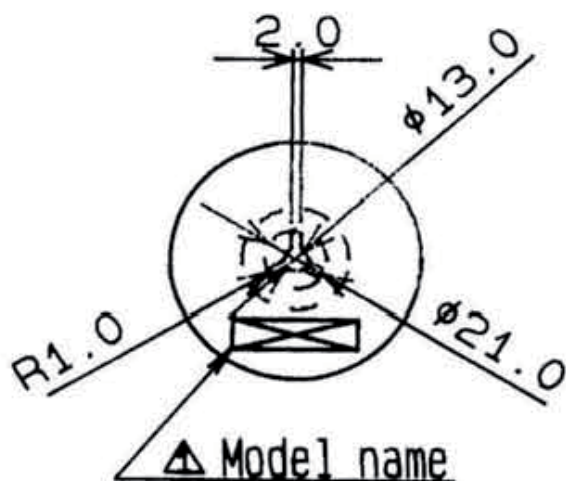

Figure 6: Direction of parts

Package

Model	Reel Diameter	Tape Width	Carrying Pitch	Number/Reel
4P	φ 250mm	24mm	12mm	1,000 p.c.s.
6P	φ 250mm	24mm	16mm	700 p.c.s.
8P	φ 250mm	24mm	12mm	1,000 p.c.s.
10P	φ 250mm	32mm	16mm	700 p.c.s.



*) "W" is applied to EIAJ regulations

Washing

- 1) Flux washing should be done without removing the tape.
If the tape is removed, it adheres less than before when it is placed back on, it's possibly causing flux inflow.
- 2) After reflow soldering, washing shall be done after keeping switch left for more 30 minutes or after the switch temperature falls to the room temperature.

Recommend to do reflow soldering or washing after confirming the trial.