

# Rotary Switches

## 10 x 10 mm Sealed Rotary DIP Switches

## RD82 Series

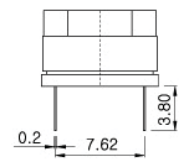
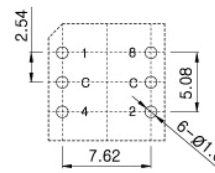
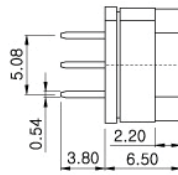
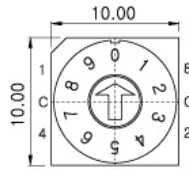

RD82(T)HR

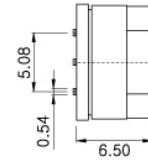
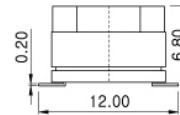
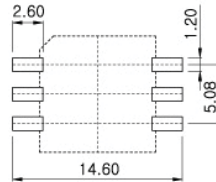
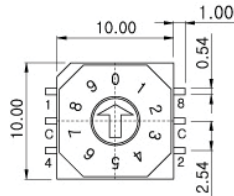

RD82(T)SO

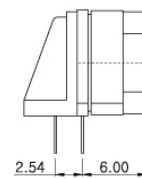
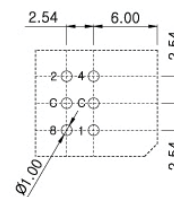
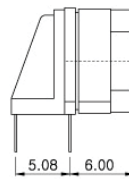
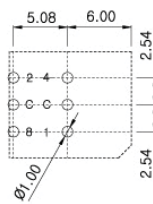
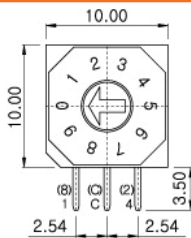

RD82(T)A20

### ROTOR TYPE

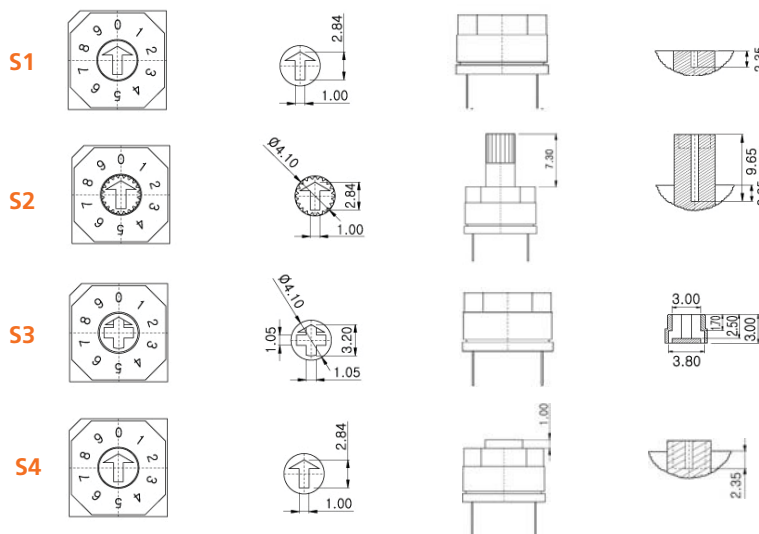

### ACCESSORIES

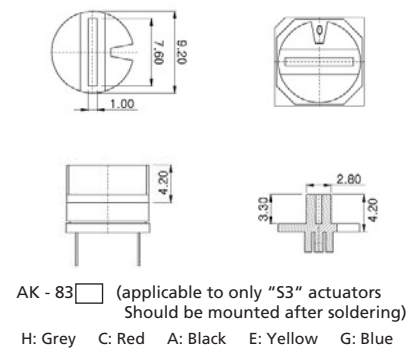

### How to order:

RD82

#### 1 SOLDERING CONDITIONS:

- blank PCB Hole Type
- T Through Hole Reflow (THR)

#### 2 TYPE OF TERMINALS:

- H THT Top Adjust Type 3:3
- HC THT Top Adjust Type 3:2
- A1 THT Right Angle Side Adjust Type with Rows Spacing 2.54 mm
- A2 THT Right Angle Side Adjust Type with Rows Spacing 5.08 mm
- S SMT Top Type 3:3
- SC SMT Top Type 3:2

#### 3 TYPE OF CASE:

- O Octagon Type
- R Round Type

#### 4 ROTOR TYPE (See Above Drawings):

- S1 Arrow Type
- S2 Shaft Type
- S3 Cross Type
- S4 Raised Type

#### 5 NO. OF POSITIONS:

- 04 4 Positions
- 06 6 Positions
- 08 8 Positions
- 10 10 Positions
- 16 16 Positions

#### 6 CODE (See Page 2):

- R Real Code
- S Complementary Code
- G Gray Code
- NR Special Code 1
- NS Special Code 2
- ND Special Code 3
- NE Special Code 4
- NF Special Code 5
- NG Special Code 6
- NH Special Code 7

#### 7 PACKAGING TYPE:

- TB Tube
- TR Tape & Reel (SMT Only)



### SPECIFICATIONS

**1. Style:**

This specification describes "Rotary Switch" mainly used as signal switch of electric devices with the general requirements of mechanical and electrical characteristics.

**1.1 Operating Temperature for PCB Hold Type: -20°C to +70°C**

**Storage Temperature Range: -40°C to +85°C**

**1.2 Operating / Storage Temperature Range for THR Type: -60°C to +125°C**

**2. Current Range:**

**2.1 None-Switching : 400mA, 24V**

**2.2 Switching : 150mA, 24V**

**3. Type of Actuation : Rotating**

**4. Test Sequence :**

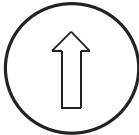
ELECTRICAL PERFORMANCE	ITEM	DESCRIPTION	TEST CONDITIONS	REQUIREMENTS
	1	Visual Examination	By visual examination check without any out pressure & testing.	There shall be no defects that affect the serviceability of the product
	2	Contact Resistance	① To be measured between the two terminals associated with each switch pole ② Measurements shall be made with a 1kHz shall current contact resistance meter	80mΩ max
	3	Insulation Resistance	250V DC, 1minute ±5seconds	100MΩ min
	4	Dielectric withstanding Voltage	250V AC(50Hz or 60Hz)shall be applied between all the adjacent terminal and between the terminal and the frame For 1 minute	There shall be no breakdown or flash over
	5	Operation Force	Applied in the direction of operation 	700gf/cm. max

MECHANICAL PERFORMANCE	6	Stop Strength	A static load of 1 kgf is applied in the vertical direction operated for a period of 15 seconds.	There shall be no sign of damage mechanically.					
	7	Soldering Heat Resistance	<p>1. Soldering Temperature:</p> <table border="1"> <tr> <td>P.C.Board terminal</td> <td>SMT Type terminal</td> </tr> <tr> <td>260℃ ±5℃</td> <td rowspan="2">See the temperature profile</td> </tr> <tr> <td>5±1sec</td> </tr> </table> <p>2. Duration of solder Immersion: 5 ±1 sec                      3. Frequency of soldering process: 2times max                      (PCB is 1.6mm in thickness)</p>	P.C.Board terminal	SMT Type terminal	260℃ ±5℃	See the temperature profile	5±1sec	As shown in item 2~6
	P.C.Board terminal	SMT Type terminal							
	260℃ ±5℃	See the temperature profile							
	5±1sec								
8	Vibration	<p>Shall be vibrated in accordance with method 201A of MIL-STD-202F</p> <p>1)Frequency: 10-55-10 Hz 1 min/cycle.                      2)Direction: 3 vertical directions including the direction of operation.                      3)Test time: 2 hours each direction</p>	As shown in item 2~6						
9	Shock	<p>Shall be shocked in accordance with method 213B condition A of MIL-STD-202F</p> <p>1)Acceleration: 50G                      2)Action time: 11 ±1 m sec.                      3)Testing direction: 6 sides.                      4)Test cycle: 3 times in each direction</p>	As shown in item 2~6						
10	Solderability	<p>1)Soldering temperature: 230 ±5℃                      2)Flux: 5-10 seconds.                      3)Duration of solder Immersion: 3 ±0.5sec</p>	No anti-soldering and coverage of dipping into solder must more than 75% was requested						

	11	Operation Life	<p>Measurements shall be made following the test set forth below:</p> <p>1)25mA, 24V DC resistive load                  2)Rate of operation: 15~20 cycles/ minute                  3)Step of operation: 10,000 steps</p>	<p>1)As shown in item 3,4                  2)Contact Resistance:                  200mΩ max                  3)Final-after test</p>
W E A T H E R 	12	Resistance Low Temperature	<p>Following the test set forth below the sample shall be left in normal temperature and humidity conditions for an hour before measurements are made:</p> <p>1)Temperature: -60℃ ±3℃                  2)Time: 96 hours</p>	As shown in item 2~6
	13	Resistance High Temperature	<p>Following the test set forth below the sample shall be left in normal temperature and humidity conditions for an hour before measurements are made:</p> <p>1)Temperature: 125℃ ±2℃                  2)Time: 96 hours</p>	<p>1)As shown in item 3~6                  2)Contact Resistance:                  200mΩ max</p>
	14	Resistance Humidity	<p>Following the test set forth below the sample shall be left in normal temperature and humidity conditions for an hour before measurements are made:</p> <p>1)Temperature: 40℃ ±2℃                  2)Relative humidity: 90~95%                  3)Time: 96 hours</p>	<p>1)As shown in item 4,6                  2)Contact Resistance:                  200mΩ max                  3)Insulation Resistance:                  10MΩ min</p>

### 5. Soldering Conditions:

#### PCB Hole Type

##### 1)Condition for Soldering

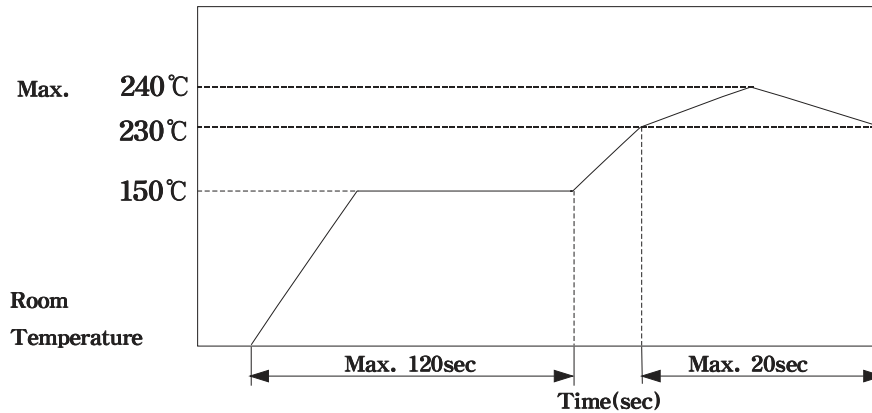

2) It should be used not to allow switch's surface temperature to exceed 240°C.

##### 3)Manual Soldering

Soldering Temperature	Max. 350°C
Continuous Soldering	Max. 3sec

##### 4)Precautions in Handling

Care should be exercised so that flux from the upper part of the printed circuit board does not adhere to the switch.

#### THR Type

##### 1)Condition for Soldering

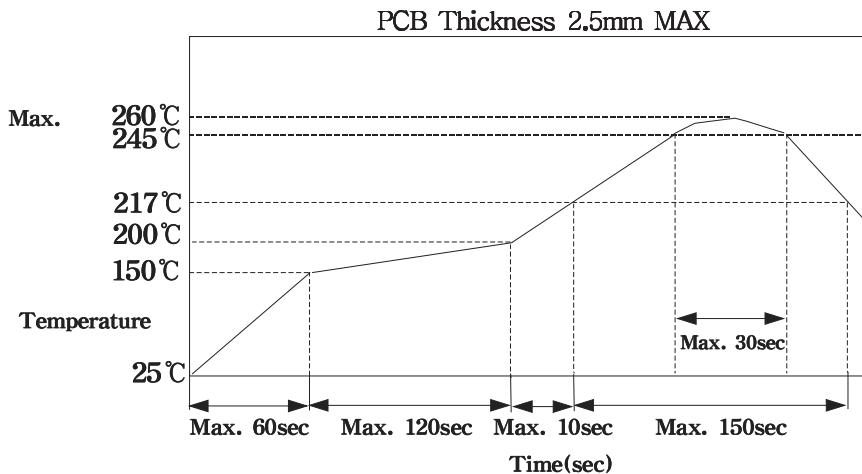

2)The condition mentioned above is the temperature on the Cu foil of PCB surface.

There are where board's temperature greatly differs from switch's surface temperature depending on board's material, size, thickness, etc. Care, therefore, should be used not to allow switch's surface temperature to exceed 260°C.

##### 3)Precautions in Handling

Care should be exercised so that flux from the upper part of the printed circuit board does not adhere to the switch.

6. This item is "ROHS" Compliant

### 7. Part List

NO	PART NAME	Q'TY	MATERIALS	TREATMENT	REMARK
1	COVER	1	PA66 (PCB Hole Type)		Print:Black
2	BASE	1	LCP (THR Type)		
3	ACTUATOR	1	PA66, STS		
4	CONTACT & TERMINAL	1	PHOSPHOR BRONZE	CONTACT AND TERMINAL PLATING: GOLD PLATING OVER NICKEL	Au 0.07 $\mu$ m Min Ni 0.1 $\mu$ m Min
5	PCB	1	EPOXY	PLATING: GOLD PLATING	Au 0.05 $\mu$ m Min
6	O-Ring	1	SILICONE		



# Rotary Switches

## 10 x 10 mm Sealed Rotary DIP Switches

## RD82 Series

### 8. Tape & Reel Packaging

