

Encoders

Watertight Rotary Encoder with Switch (IP67)

P/N: **EC97BN10F20PNA**

15.0mm Thread Type



DIMENSIONS		TOLERANCE
0.00 TO	10.00mm	±0.20mm
10.01 TO	20.00mm	±0.25mm
20.01 TO	30.00mm	±0.30mm
30.01	↑	±0.40mm

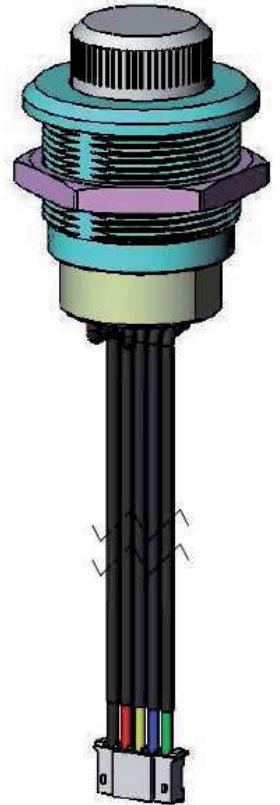
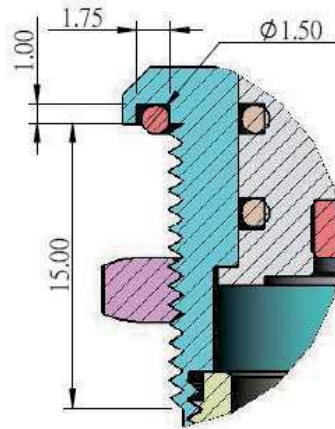

Part Number:
EC97BN10F20PNA

Bushing: Threaded Type 2: 15mm, M25x1.0P
Wire Gauge: 1007 26AWG
Wire length: 160 mm
Connector: 5P Housing, 2.0 mm Pitch

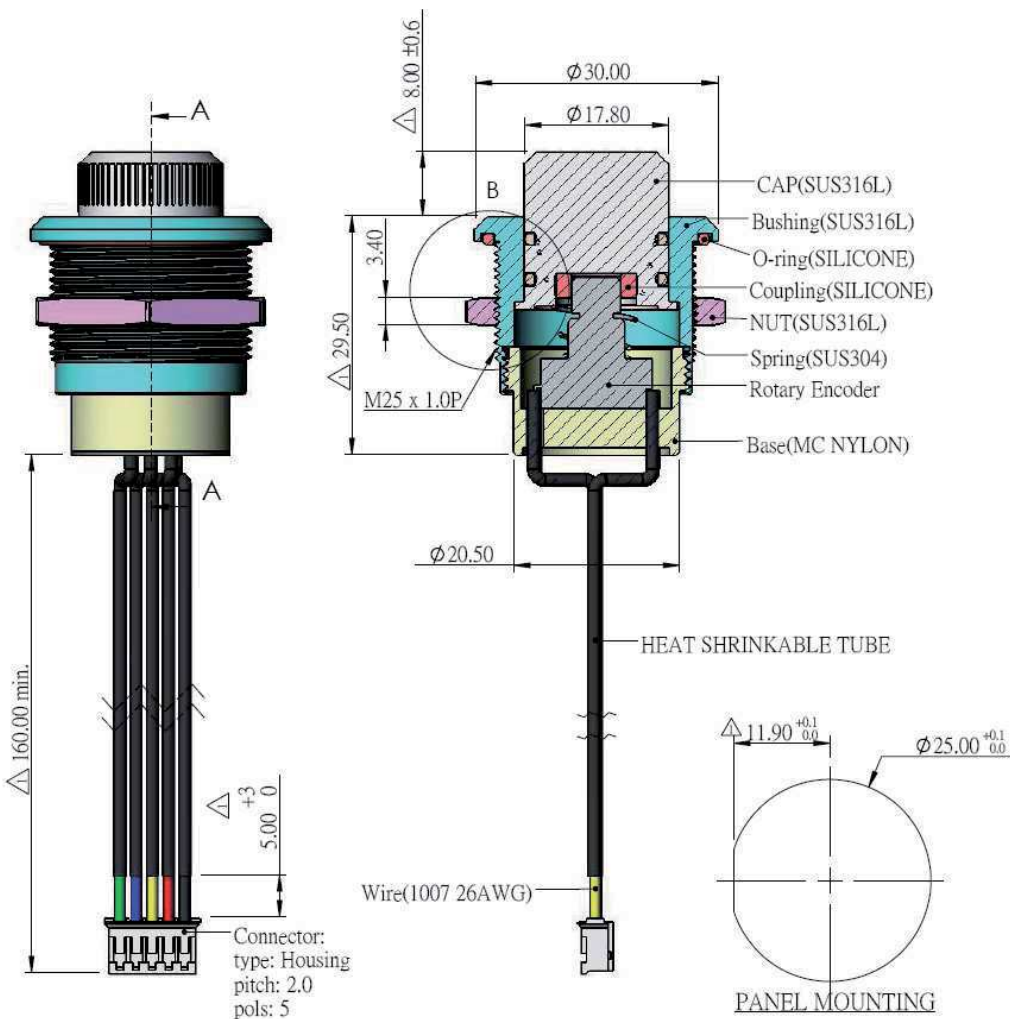

All specifications are restricted to QA test criteria.
DRW: D. L. JIN, CHK: D. F. LEE, APP: H. Z. QIU, DC: 2013-05-07, UPD: 2025-05-19.

Encoders

Watertight Rotary Encoder with Switch (IP67)

P/N: EC97BN10F20PNA

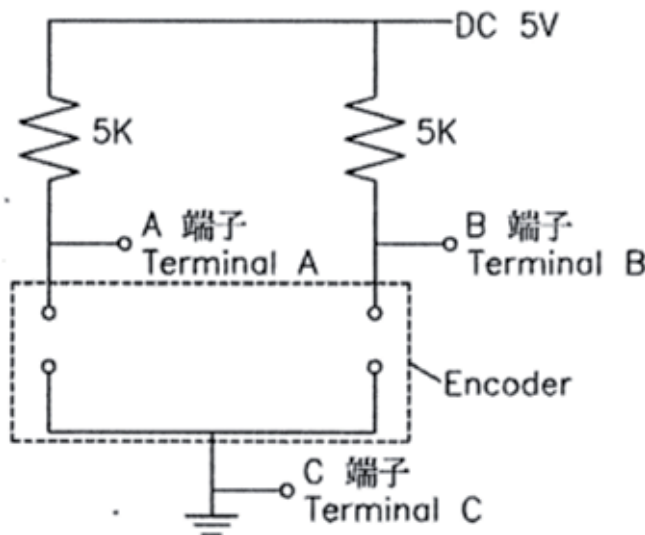
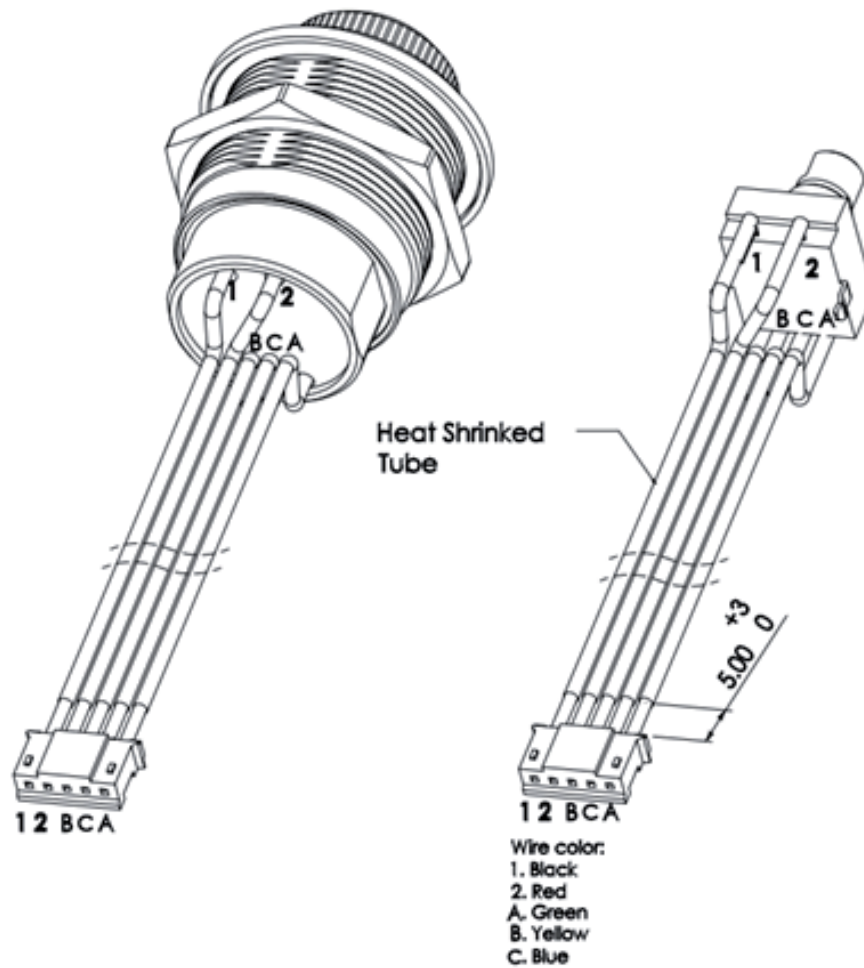

Fig(1)

1. Wire: UL1007 26AWG, 160mm long.
2. Connector: 5P housing. Pitch 2.0mm.
3. Connector end: 5mm without tube.

DIMENSIONS OF ROTARY ENCODER

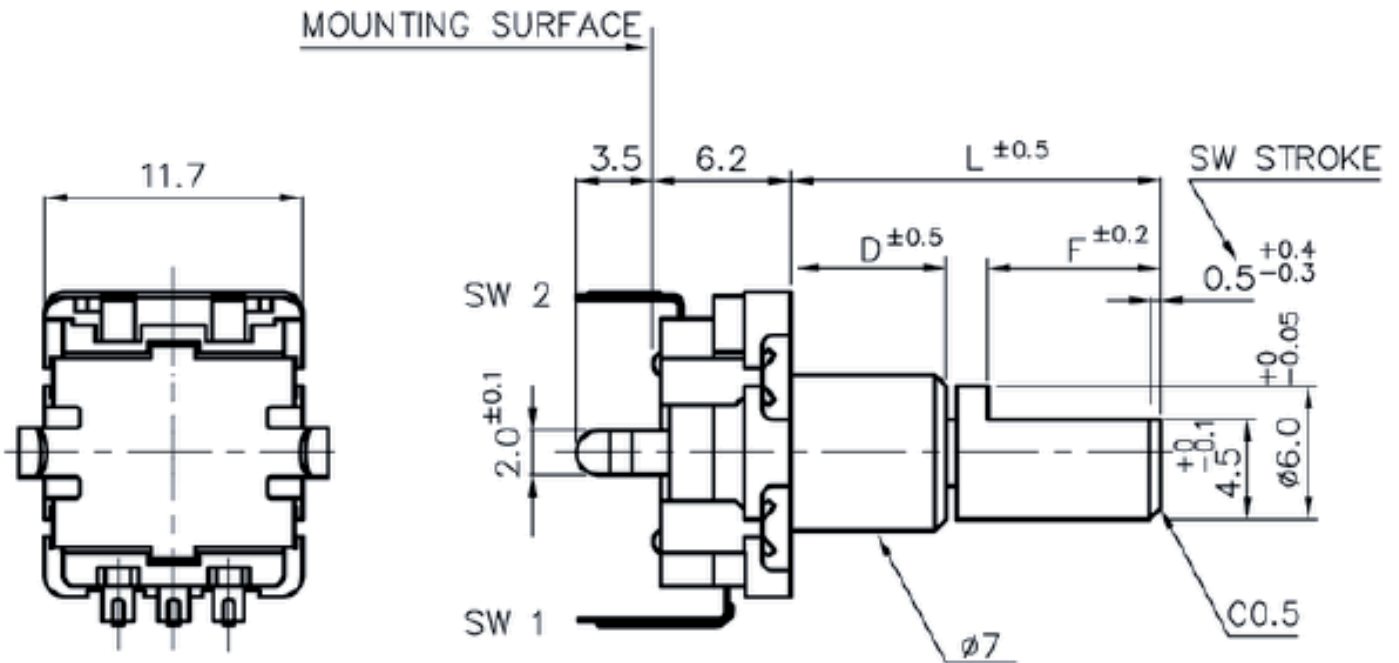

DIMENSIONS	TOLERANCE
0.00 TO 10.00mm	$\pm 0.20\text{mm}$
10.01 TO 20.00mm	$\pm 0.25\text{mm}$
20.01 TO 30.00mm	$\pm 0.30\text{mm}$
30.01 ↑	$\pm 0.40\text{mm}$

D = 5 mm
L = 10 mm
F = 3.5 mm



SHAFT FLAT IS
OPTIONAL ANGLE

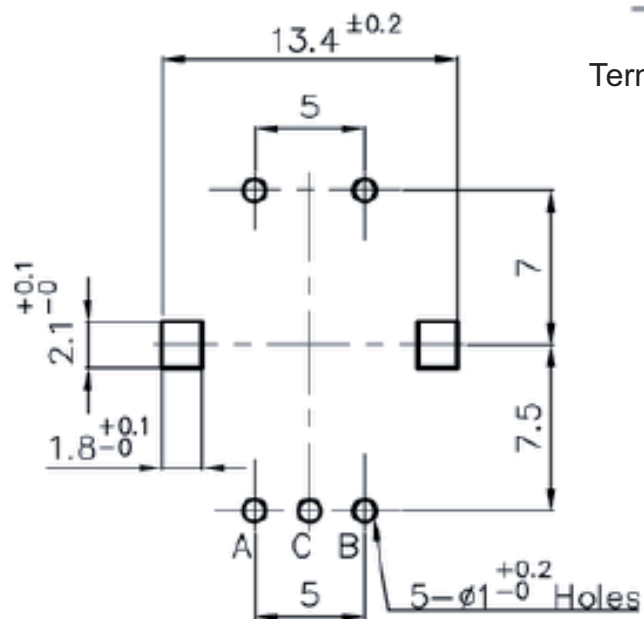
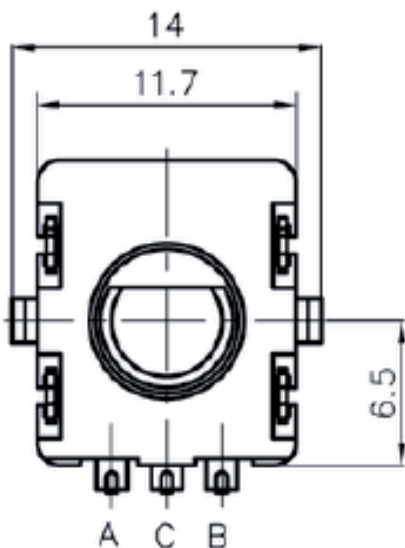

P.C.B. LAYOUT (only for non-wire version)

SPECIFICATIONS OF ROTARY ENCODER

1. General:

1.1 Scope:

This specification applies to 11mm size low-profile rotary encoder (incremental type) for microscopic current circuits, used in electronic equipment.

1.2 Standard atmospheric conditions:

Unless otherwise specified. The standard range of atmospheric conditions for making measurements and tests is as follows:

Ambient temperature	15~35°C
Relative humidity	25~85%
Air pressure	86~106kpa

If there is any doubt about the results, measurements shall be made within the following limits:

Ambient temperature	20±1°C
Relative humidity	63~67%
Air pressure	86~106kpa

1.3 Operating temperature range: -10°C to +70°C

1.4 Storage temperature range: -40°C to +85°C

2. Construction:

2.1 Dimensions: Dimensions refer to drawing.

3. Rating:

3.1 Rated voltage: D.C.5V 10mA (1mA min)

4. Electrical characteristics:

4.1 Output signal: The broken line shows detent stability point.

軸回轉方向 Shaft rotational direction	信號 Signal	出力波形 Output
順時針方向 C.W.	A (A-C 端子間) A (Terminal A-C)	OFF ON
	B (B-C 端子間) B (Terminal B-C)	OFF ON
逆時針方向 C.C.W.	A (A-C 端子間) A (Terminal A-C)	OFF ON
	B (B-C 端子間) B (Terminal B-C)	OFF ON

4.2 Resolution:

Number of pulses in 360° rotation: 20 pulses/360° for each phase.

4.3 Switching characteristics:

Measurement shall be made under the condition follows, shaft rotational speed 360°/S.

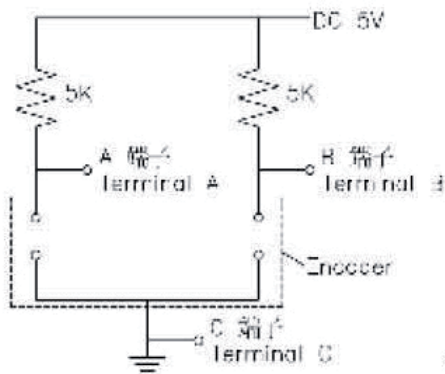

Fig(1)

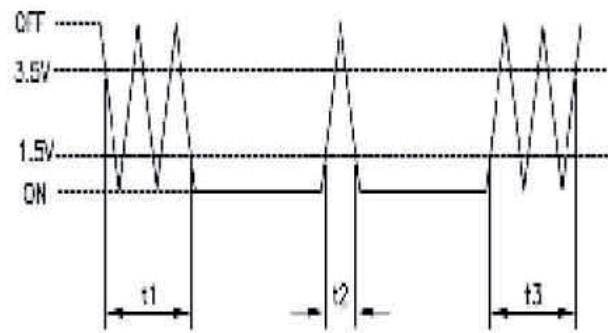

Fig(2)

* Code - ON area: The area which the voltage is 1.5 or less.

* Code - OFF area: The area which the voltage is 3.5 or more.

4.3.1 Chattering:

Specified by the signal's passage time from 3.5V to 1.5V or from 1.5V to 3.5V of each switching position. (code OFF-ON or ON-OFF) $t_1, t_3 \leq 2\text{ms}$

4.3.2 Sliding noise (bounce):

Specified by the time of voltage change exceed 1.5V in code-ON area: $t_2 \leq 2\text{ms}$

4.3.3 Sliding noise:

The voltage change in code-OFF area: 3.5V min.

4.4 Phase-difference:

Measurement shall be made under the condition which the shaft is rotated in 360°/S constant speed: $\Delta t = T/4 \pm T/6$ min.

順時針方向(C.W)

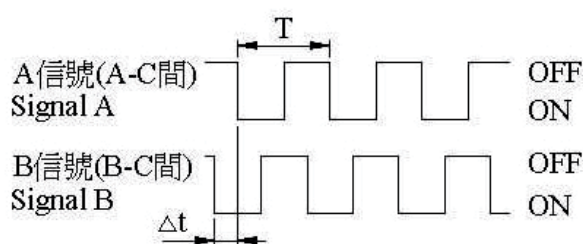

反時針方向(C.C.W)

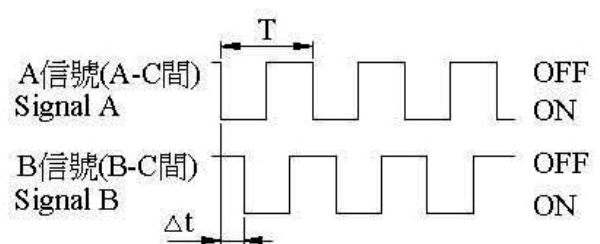

4.5 Dielectric strength:

A voltage of 300V A.C. shall be applied for 1 min between individual terminals and bushing. (Leak current 1mA)

4.6 Insulation resistance:

Measurement shall be made under the condition which a voltage of 250V D.C. is applied between individual terminals and bushing: 100M Ω min.

5. Mechanical characteristics:

5.1 Total rotational angle: 360° (Endless)

5.2 Rotational torque: 200gf.cm Max (19.6mN.m Max)

5.3 Terminal strength:

A static load of 300gf.cm (29.4mN.m) shall be applied to the tip of terminals for 1 minute in any direction.

5.4 Push-pull strength of shaft:

Push and pull static load of 10kgf (98.1N) shall be applied to the shaft in the axial direction for 10sec. (After installing)

5.5 Shaft wobble:

A momentary load of 500gf to be applied at the point 5mm from the tip of the shaft in a direction perpendicular to the axis of shaft: $0.8 \times L / 30\text{mm}$ Max. L: Measurement point from mounting surface.

6. Endurance characteristics:

6.1 Rotational life (No load): 15,000 cycles (500 continuous cycles per 1 hour,
1 cycle: rotate 360° ccw, rotate 360° cw)

Rotational torque: Relative to the previously specified value +10% / -30%.

Chattering: $t_1, t_3 \leq 5\text{ms}$

SPECIFICATIONS OF PUSH SWITCH

1. Switch rating (resistor load): D.C. 16V 3A (10mA min.)
2. Electrical characteristics:
 - 2.1 Contact resistance: 100m Ω Max.
(Measure by the D.C 5V 1mA voltage drop method.)
 - 2.2 Insulation resistance: D.C 250V 100m Ω Max.
Measure shall be made under the condition which a voltage of D.C 250V is applied between individual terminals and bushing.
 - 2.3 Dielectric strength: A.C 300V 1min. (leak current 1mA)
A voltage of A.C 300V shall be applied for 1 min. Between individual terminals and bushing. (leak current 1mA)
3. Mechanical characteristics:
 - 3.1 Contact arrangement: S.P.S.T. (Push ON)
 - 3.2 Switching stroke: 0.5 (+0.4/-0.3) mm
 - 3.3 Switch operating force: 600 \pm 300gf.cm (59 \pm 29.4mN.m)
4. Endurance characteristics:
 - 4.1 Operating life: 25,000 cycles, (500 continuous cycles per 1 hour)
Switch contact resistance: 200m Ω Max.

APPLICATION NOTES

1. Avoid storing the products in a place at high temperature, high humidity and in corrosive gases.
2. The encoders pulse count method should be designed with taking operating speed, sampling time and the design of the micro computer software, ect.
3. Operating temperature range: $-10^{\circ}\text{C} \sim +70^{\circ}\text{C}$.
4. Storage temperature range: $-40^{\circ}\text{C} \sim +85^{\circ}\text{C}$.
5. Dip soldering: To be performed in 4 seconds within $260\pm 5^{\circ}\text{C}$.
6. Manual soldering: To be performed in 3 seconds within $300\pm 5^{\circ}\text{C}$.
7. Regarding preheating, the entire flow duration should not exceed 2 minutes, and soldering surface temperature (undersurface of PCB) shall be settled within 100°C .