

# Encoders

## 11mm Slim Type Rotary Encoders

## EC89 Series

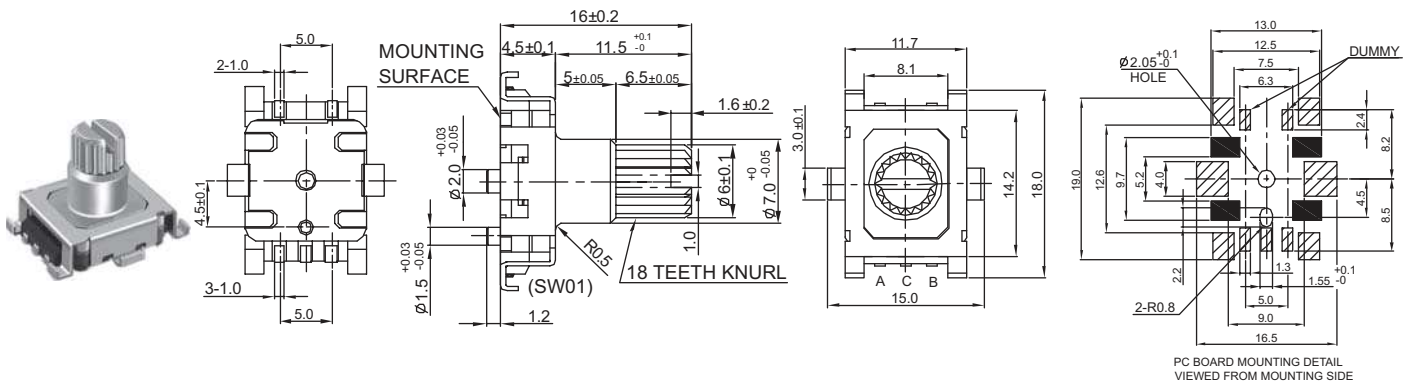

EC895NBF SMT\_ Without Switch, SMT Type

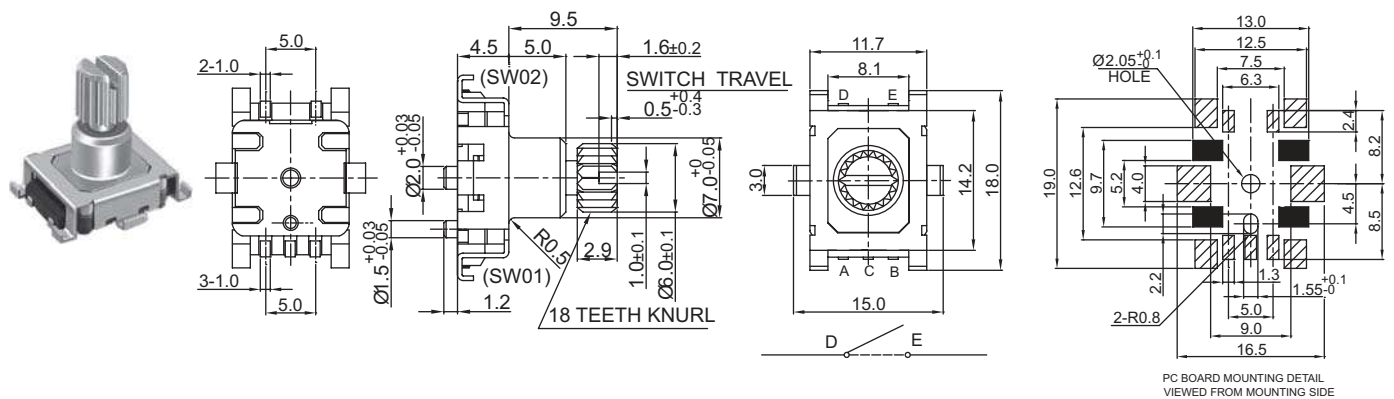

EC89SD5NBF SMT\_ With Switch Travel 0.5mm, SMT Type

### How to order:

EC89 1 2 3 4 5 6 7 8 9 10

#### 1 SWITCH FUNCTION:

S With Switch  
blank Without Switch

#### 2 SWITCH TRAVEL (EC89S only)

Code	Travel
D	Switch Travel 0.5
E	Switch Travel 1.5

#### 3 TYPE OF ENCODER:

Code	Terminals
V	Vertical P.C.B.

#### 4 LENGTH OF BUSHING:

5 5mm (Standard)

#### 5 TYPE OF BUSHING:

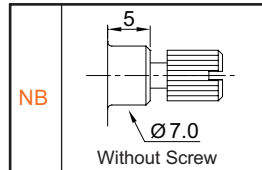

#### 6 FRAME

F With Frame

#### 7 TYPE OF TERMINALS:

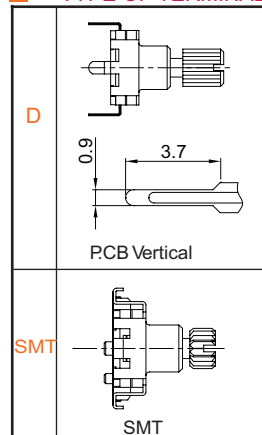

#### 8 LENGTH OF SHAFT (L):

... See drawings

#### 9 TYPE OF SHAFT:

Code	Shaft
K	Zinc Diecast

#### 10 OUTPUT PULSE & DETENT:

15P30C 15 Pulse 30 Deten  
15P 15 Pulse none Deten

