

### LED COLOR:

CODE	COLOR	TERMINAL
BO	BLUE	1 2
	ORANGE	1 3
RG	RED	1 2
	GREEN	1 3
BG	BLUE	1 2
	GREEN	1 3

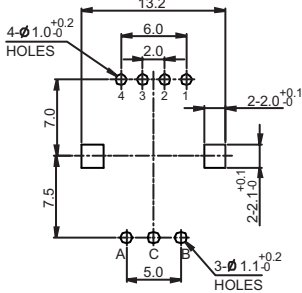

P.W.B MOUNTING DETAIL  
(TOLERANCE ±0.1)  
VIEWED FROM MOUNTING SIDE  
(P.C.B) t=1.5mm

## Vertical Type Knurled Shaft

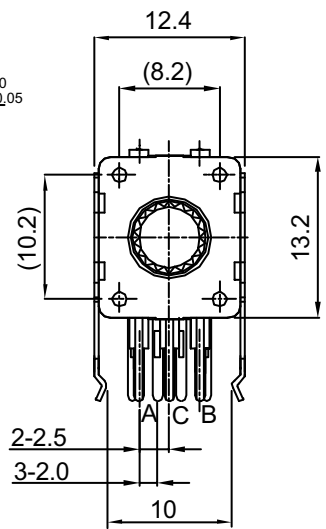
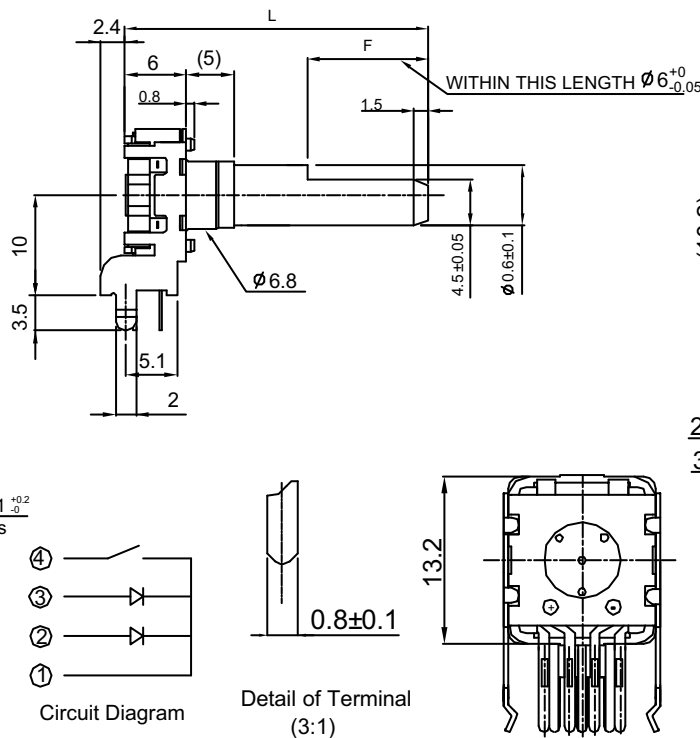

### LED COLOR:

CODE	COLOR
O	ORANGE
B	BLUE
R	RED
G	GREEN

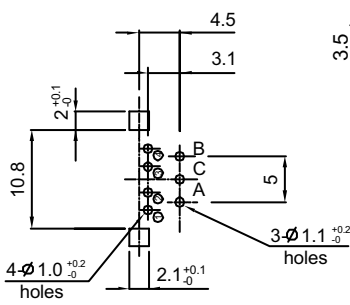

Mounting hole detail  
Viewed from mounting side  
P.C.B t=1.6mm

## Horizontal Type Flat Shaft

### How to order:

EC7

- 1 LED COLOR (dual-color if with switch):**  
 C Red  
 D Orange  
 F Green  
 G Blue
- 2 SWITCH:**  
 0 Without Switch (for single color)  
 1 With Switch (for dual colors)
- 3 BUSHING (drawing 1):**  
 Blank Without Bushing (if with Switch)  
 B With Bushing (only if without Switch)
- 4 TYPE OF TERMINAL (drawing 2):**  
 2 PC Board (horizontal)  
 4 PC Board (vertical)
- 5 "LB" Length (drawing 3):**  
 Blank 5mm (Standard)  
 A 0.6mm (vertical type only)  
 C 1.5mm (vertical type only)
- 6 SHAFT SHAPE (drawing 4):**  
 K Knurled Type with Length 25mm  
 F Flat Type with different Length (different length see page 2)
- 7 PULSE AND DETENT:**  
 N 24 Pulse none Detent  
 D 24 Pulse with 24 Detents

Drawing 1: Bushing

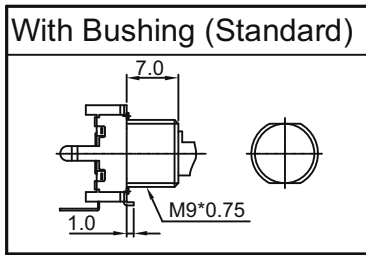

Drawing 2: Type of Terminal

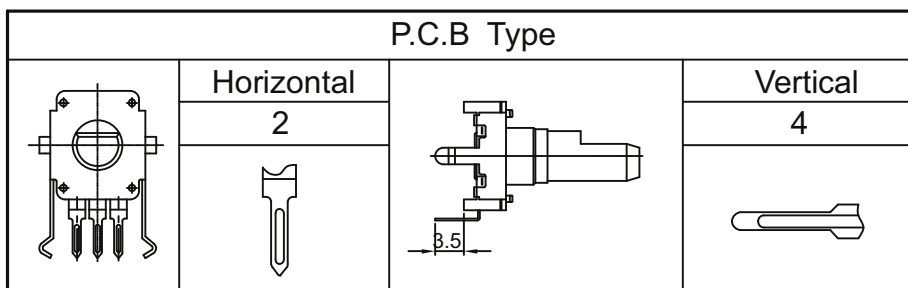

Drawing 3: "LB" Length

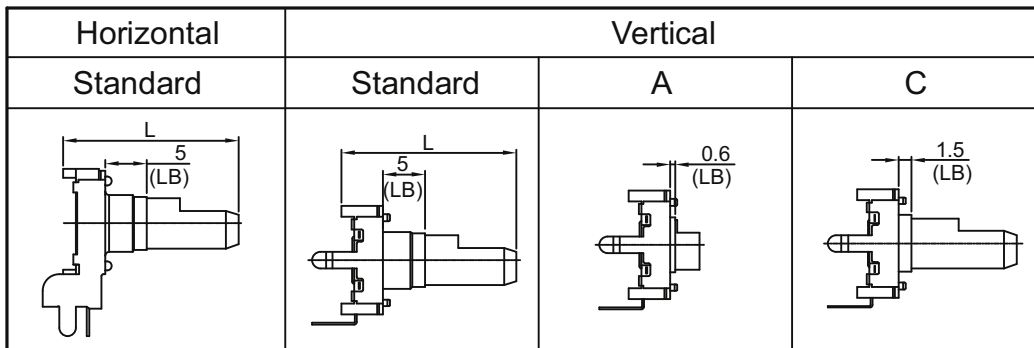

Drawing 4: Shaft Shape

F - Type														
With Bushing							Without Bushing							
	L	15	17.5	20	22.5	25		30	L	15	17.5	20	25	30
	F	7	5	7	7	12		12	F	7	5	7	12	12

### ROTARY ENCODER SPECIFICATION

#### 一, 一般事項 General

##### 1~1 適用範圍 Application

適用於電子機器的微小電流回路用之12mm迴轉式位元產生器

This specification applies to 12mm size rotary encoder for microscopic current circuit, used electronic equipment.

##### 1~2 標準狀態 Standard atmospheric conditions

若無特別規定限制, 測試時需要在標準狀態範圍下, 此範圍如下:

Unless otherwise specified, the standard range of atmospheric conditions for making measurements and tests is as follows.

溫度 Ambient temperature: 15°C to 35°C

相對濕度 Relative humidity: 25% to 85%

氣壓 Air pressure: 860mbar to 1060mbar

但對此標準狀態之測定值發生判定疑問或有特別要求則以基準狀態為準測定, 此範圍如下:

If there is any doubt about the results, measurements shall be made within the following:

溫度 Ambient temperature: 20±2°C

相對濕度 Relative humidity: 65±5%

氣壓 Air pressure: 860mbar to 1060mbar

##### 1~3 使用溫度範圍

Operating temperature range : -40°C to +85°C

#### 二, 構造, 尺寸 Construction and dimensions 依組立圖 Refer to attached drawing

#### 三, 定格電壓 Rated voltage: DC 5V 0.5mA

### 四. 電氣性能 Electrical Characteristics

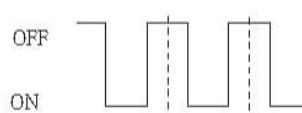
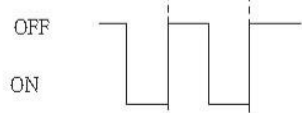
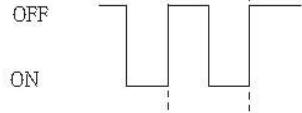
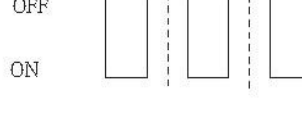
NO.	項目 item	條件 conditions	規格 specifications	
4-1	輸出信號 output signal format	<圖一> <fig. 1>	A . B 二信號的輸出時間相位差, 詳細如<圖一>所示. (圖中虛線表示掣子點定位置) 2. Phase-different signals (Signal A. & signal B) Details shown in < fig.1 > The detent position will always be aligned with A-phase but B-phase is no specification. (The broken line shows detent position of with detent type.)	
			軸回轉方向 Shaft rotational direction	信號 Signal
		順時針方向 C. W.	A (A-C 端子間) A (Terminal A-C)	
			B (B-C 端子間) B (Terminal B-C)	
		反時針方向 C. C. W.	A (A-C 端子間) A (Terminal A-C)	
			B (B-C 端子間) B (Terminal B-C)	
4-2	分解能 Resolution	旋轉一圈所產生脈波數目. Number of pulses in 360° rotation .	各相24脈波/360° 24 pulses / 360° for each phase	

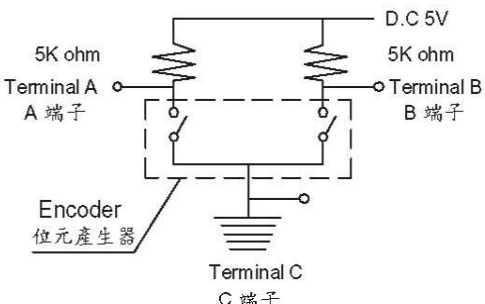
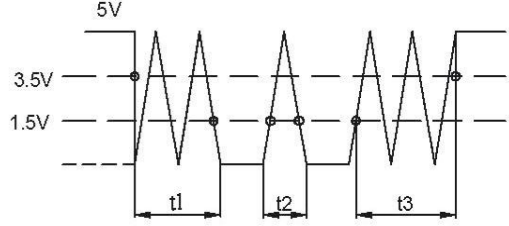
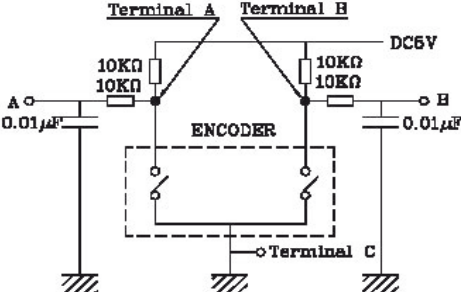
NO.	項目 item	條件 conditions	規格 specifications
4-3	切換特性 Switching	<p>                         切換測定回路如&lt;圖二&gt;所示, 測定時軸回轉速度為每秒鐘回轉360°。                          Measurement shall be made under the condition as follows .                          (1). Shaft rotational speed: 360° /S                          (2). Test circuit : &lt; fig. 2 &gt; .                     </p> <p style="text-align: center;">&lt; 圖二 &gt; &lt; fig. 2 &gt;</p>  <p>                         位元OFF狀態：輸出電壓3.5V以上的狀態稱之。                          位元ON狀態：輸出電壓1.5V以下的狀態稱之。                          Code - OFF area: The area which the voltage is 3.5V or more .                          Code - ON area: The area which the voltage is 1.5V or less .                     </p>	<p style="text-align: center;">&lt; 圖三 &gt; &lt; fig.3 &gt;</p> 
1)	震顛雜音 Chattering	<p>                         如&lt;圖三&gt;位元由狀態OFF→ON或ON→OFF變化時, 輸出電壓在1.5V~3.5V 的切換時間稱之 .                          Details shown in &lt; fig.1 &gt; Specified by the signals passage time from 3.5V to 1.5V or from 1.5V to 3.5V of each switching position ( code OFF→ON or ON →OFF ) .                          注意：針對震顛雜音(t1 , t3)部分，請於訊號                          抓取上加以遮蔽，進行過濾雜訊。                          建議追加過濾迴路，如&lt;圖四&gt;所示。                          Note : To avoid chattering( t1 , t3), please consider masking time and adding C/R filters on your circuit for pulse count design, as show in &lt;fig. 4&gt; .                     </p> <p style="text-align: center;">&lt;圖四&gt; &lt;fig. 4&gt;</p> 	<p style="text-align: center;"><math>t_1, t_3 \leq 3ms</math></p>

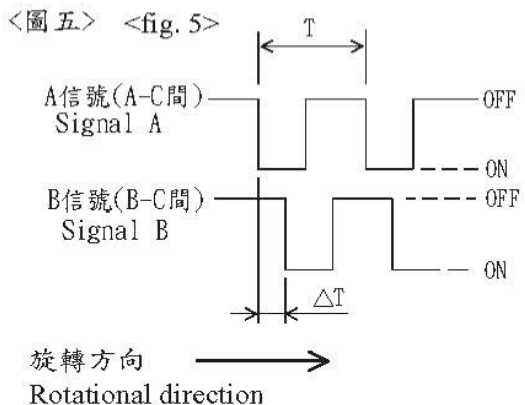
NO.	項目 item	條件 conditions	規格 specifications
2)	跳躍旋轉雜音 Rotational noise (Bounce)	<p>位元在ON的狀態時，電壓超過1.5V以上的時間視為當在位元ON狀態時，與震顛雜音(t1或t3)時間間隔小于1ms時，則該跳躍雜音視為震顛雜音的一部份。</p> <p>當在位元ON狀態時，兩個跳躍雜音間的間隔小于1ms時，則視為同一跳躍雜音。</p> <p>Specified by the time of voltage change exceed 1.5V in code - ON area .</p> <p>When the bounce has code - ON time less than 1ms between chattering (t<sub>1</sub> or t<sub>3</sub>), the voltage change shall be regarded as a part of chattering</p> <p>When the code - ON time between 2 bounces is less than 1ms, they are regarded as 1 linked bounce</p>	t <sub>2</sub> ≤ 2ms
3)	旋轉雜音 Rotational noise	<p>位元OFF狀態時的電壓變動。</p> <p>The voltage change in code-OFF area</p>	3.5V 以上 3.5V MIN.
4-4	相位差 Phase-difference	<p>以定速每秒鐘旋轉360°測定之。</p> <p>Measurement shall be made under the condition which the shaft is rotated in 360°/S( constant speed)</p> <p>&lt;圖五&gt; &lt;fig. 5&gt;</p>  <p>如圖五所示，<math>\Delta T \geq 3.5ms</math></p> <p>in &lt; fig. 5 &gt;</p>	如圖五所示， $\Delta T \geq 3.5ms$ in < fig. 5 >
4-5	絕緣阻抗 Insulation resistance	<p>外加電壓250V D.C 1mA 於取付板與任一端子間。</p> <p>Measurement shall be made under the condition which a voltage of 250V D.C 1mA is applied between individual terminals and bracket</p>	取付板與端子間100MΩ以上。 Between individual terminals and bushing 100M Ω MIN .

NO.	項目 item	條件 conditions	規格 specifications
4-6	耐電壓強度 Dielectric strength	於取付板與任一端子間外加電壓300V A.C.1 分鐘或外加A.C 360V 2 秒鐘測定。 A voltage of 300V A.C. shall be applied for 1 min between individual terminals and breaket. Or a voltage of 360V A.C. shall be applied for 2 sec. (Leak current : 1mA)	無損傷, 短路及絕緣破壞現象。 Without arcing or breakdown.

### 五. 機械性能 Mechanical characteristics

NO.	項目 item	條件 conditions	規格 specifications
5-1	全回轉角度 Total rotational angle		360° 回轉 360° ( Endless )
5-2	掣子脫出力 Detent torque		5±3mN.m ( 51±30.6gf.cm )
5-3	掣子點數及位置 Number and position of detents		24點掣子 24 detents 每點角度: 15° ± 3° Step angle : 15° ± 3°
5-4	端子強度 Terminal strength	外加靜重3N(0.31kgf)之力于端子前端之任意方向10秒。 A static load of 3N shall be applied to the tip of terminals for 10sec in any direction .	端子無損壞或顯著鬆動, 但是端子可允許彎曲。 Without excessive play in terminals or poor contact.
5-5	軸擠壓引張強度 Push - pull strength of shaft	在軸之方向加壓力或張力之靜負荷50N(5.1Kgf) 10秒 ( 實裝狀態 ) 。 Push and pull static load of 50N shall be applied to the shaft in the axial direction for 10sec.(After soldering of the PC board)	不可有電氣或機械上的異常 Without damage to. or excessive play in shaft.No excessive abnormality in rotational feeling. And electrical characteristies
5-6	軸鬆動 Shaft wobble	軸前端5mm處加上50mN.m(0.51Kgf.cm)的力矩。 A momentary load of 50mN.m shall be applied at the point 5mm from the tip of the shaft in a direction perpendicular to the axis of shaft .	1.0xL/30mm.p-p以內 1.0xL/30mm.p-p MAX. (L 為軸的取付長度) (L:Shaft Length)

NO.	項目 item	條件 conditions	規格 specifications
5-7	軸垂直側壓強度 Side thrust Strength of shaft	軸前端5mm處,加上20N(2.04Kgf)的靜荷重10秒。 A load of 20N shall be applied at the point 5mm from the tip of the shaft in a direction perpendicular to the axis of shaft.(After soldering of PC board)	不可有電氣或機械上的異常 Without excessive play or bending in shaft. No mechanical abnormality.
5-8	軸回轉間隙 Shaft play in rotational wobble	使用角度板測定之 Measure with jig for rotational angle.	4° 以內 4° MAX.

### 六. 耐久性能 Endurance characteristics

NO.	項目 item	條件 conditions	規格 specifications
6-1	回轉壽命 Rotational life	無任何電氣負荷下,軸以每小時600~1000回轉的速度下,持續進行30,000回轉。 (1回轉為360°往返各一次) The shaft of encoder shall be rotated to 30,000 cycles at a speed of 600~1000 cycles per hour without electrical load ,after which measurement shall be made .	震顛雜音: $t_1, t_3 \leq 5mS$ 跳躍旋轉雜音: $t_2 \leq 3mS$ 相位差: $\Delta T \geq 2.5mS$ 付掣子點機種需有掣子點的感觸。 Chattering: $t_1, t_3 \leq 5mS$ Bounce: $t_2 \leq 3mS$ Phase-difference: 2.5msec MIN. Detent feeling has to remains. (Applied for detent type)



### 七. 焊錫耐熱性 Soldering condition

NO.	項目 item	條件 conditions	規格 specifications
7-1	人工手焊 Manual Soldering	<p>溫度350°C以下, 時間3秒鐘以內.</p> <p>Bit temperature of soldering : 350°C or less</p> <p>Application time of soldering : 3sec. Max.</p>	<p>不可發生絕緣體變形, 破損 以及感觸異常.</p> <p>There shall be no deformation or cracks in molded part .No excessive abnormality in rotational</p>
7-2	自動焊錫 Dip soldering	<p>使用基板:t1.5兩面銅箔積層板.</p> <p>Printed wiring board : Single-sided copper clad laminate board with thickness of 1.5mm .</p> <p>預熱條件: 基板表面溫度100°C以下, 時間1分鐘以內</p> <p>Preheating :</p> <ul style="list-style-type: none"> <li>• Surface temperature of board : 100°C or less</li> <li>• Preheating time : within 1 min .</li> </ul> <p>焊錫爐條件: 溫度 260 ± 5°C , 時間 3 ± 1 秒以內 .</p> <p>Soldering :</p> <ul style="list-style-type: none"> <li>• Solder temperature : 260 ± 5°C .</li> <li>• Immersion time : 3 ± 1 sec .</li> </ul> <p>以上工程以一次或兩次為宜 .</p> <p>Apply the above soldering process for 1 or 2 times .</p>	<p>不可發生絕緣體變形, 破損 以及感觸異常.</p> <p>There shall be no deformation or cracks in molded part .No excessive abnormality in rotational</p>

### PUSH MOMENTARY SWITCH SPECIFICATION

#### 1. 定格容量 ( 抵抗負荷 ) D.C. 16V3A

Switch rating ( Resistor load ) D.C. 16V3A

#### 2. 電氣性能 ( Electrical characteristics )

NO.	項目 item	條件 conditions	規格 specifications
2-1	接觸阻抗 Contact resistance	以D.C. 5V 10mA 電壓降下法測定之。 Measured by the 10mA 5V D.C. voltage drop method .	100 mΩ 以下 100 mΩ MAX.
2-2	震顛雜音 Chattering	一周期動作 ( OFF - ON - OFF ) 為1秒鐘。 Switch is operated at the rate of 1 cycle 1 sec. The 1 cycle shall be OFF - ON - OFF .	10msec 以下 Less than 10 msec .
2-3	絕緣阻抗 Insulation resistance	外加D.C. 250V 1mA 于端子與取付板間。 Measurement shall be made under the condition which a voltage of 250V D.C. 1mA is applied between individual terminals and bushing .	端子與取付板間100MΩ 以上 Between individual terminals and bushing 100MΩ MIN .
2-4	耐電壓 Dielectric strength	端子與取付板間外加A.C. 300V 1 分鐘或外加A.C. 360V 2 秒鐘測定, ( Leak 電流: 1mA ) A voltage of 300V A.C. shall be applied for 1 min or a voltage of 360V A.C. shall be applied for 2 sec between individual terminals and bushing . ( Leak current : 1mA )	無損傷, 變形或絕緣破壞 現象。 Without damage to parts arcing or breakdown .
	備注 Note	軸與開關端子間絕緣。 Shaft is insulated from switch terminal .	

#### 3. 機械性能 ( Mechanical characteristics )

NO.	項目 item	條件 conditions	規格 specifications
3-1	開關回路, 接點數 Contact arrangement		單極單投 ( PUSH ON ) S.P.S.T ( PUSH ON )

NO.	項目 item	條件 conditions	規格 specifications
3-2	開關移動量 Switching stroke		+0 0.5-0.3 mm
3-3	開關作動力 Switch strength		400 ± 200gf

#### 4. 耐久性能 (Endurance characteristics)

NO.	項目 item	條件 conditions	規格 specifications
4-1	負荷壽命特性 Operating life	<p>額定負荷狀態下動作 20,000 回,但是每 5,000 回測定一次.</p> <p>The shaft of switch shall be 20,000 times at a speed of 500 times per hour without electrical load, after which measurements shall be made, However, an interim measurement shall be made immediately after 5,000 times.</p>	<p>接觸阻抗: 200mΩ 以下 其它項目均需滿足初期規格值.</p> <p>Switch contact resistance: 200mΩ MAX. Except above items. specification in clause 2.1~4 and 3.1~3 shall be satisfied.</p>

### L. E. D. COMMON SPECIFICATIONS

#### 一. 回路: Circuit:

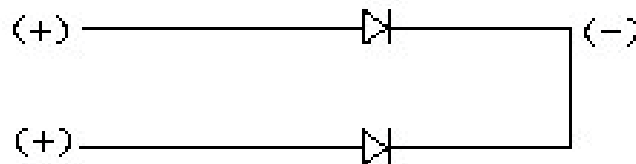

#### 二. LED 特性

##### LED Characteristic

1. 逆電流: [IR]=10uA [VR]=5V  
Reverse Current: [IR]=10uA [VR]=5V
2. 反轉電壓: 5V  
Reverse Voltage: 5V
3. 工作溫度: -40 °C~85°C  
Operating Temperature: -40°C~85°C

4

發光色 Emitted color	功率消耗 Power dissipation	直流正向電流 DC Forward Current	Vf(V) (@IF=20mA)			
			Though-hole type		Surface-mount type	
			Max.	Typ.	Max.	Typ.
藍色 Blue color	100mW	20mA	3.2	2.8	3.5	2.5
紅色 Red color	63mW	25mA	2.6	1.7	2.5	2
綠色 Green color	63mW	20mA	2.6	2.2	2.5	2
橘色 Orange color	75mW	30mA	—	—	2.5	2.1
白色 White Color	100mW	25mA	—	—	4	3.3