

Tactile Switches

0.35 x 3.7 x 3.7 mm Ultra-Low Thin Tactile Switches

TP34 Series

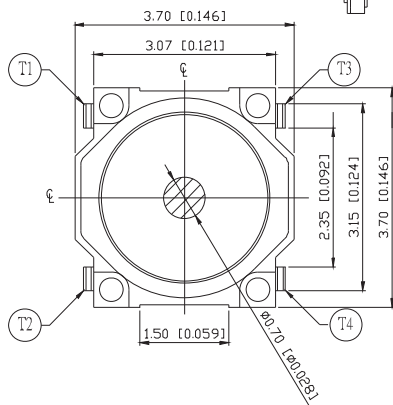
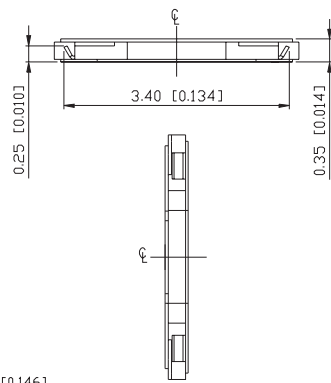
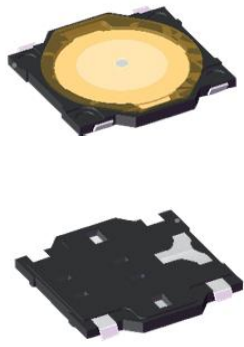

P.C.B LAYOUT & CIRCUIT

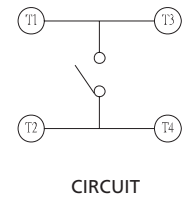
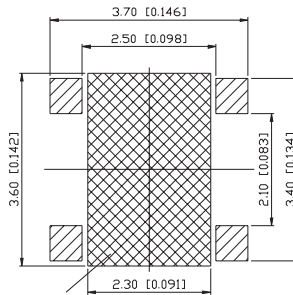

Any land pattern or vias shall not be provided at 2.30x3.60 area.

SOLDERING PROCESS

- > Hand Soldering : Use a Soldering Iron of 30 Watts, controlled at 350°C approximately 5 Sec. while Applying
- > Reflow Soldering : Vapor Phase & Reflow Soldering can be applied
- > Any Flux enters the Switch may fail the Conductivity
- > Temperature Profile :

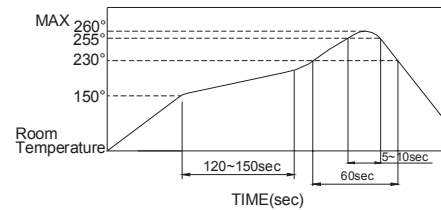

TAPE & REEL PACKING

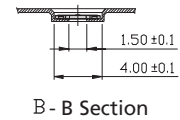
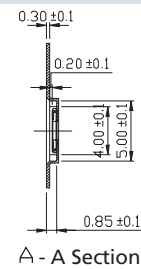
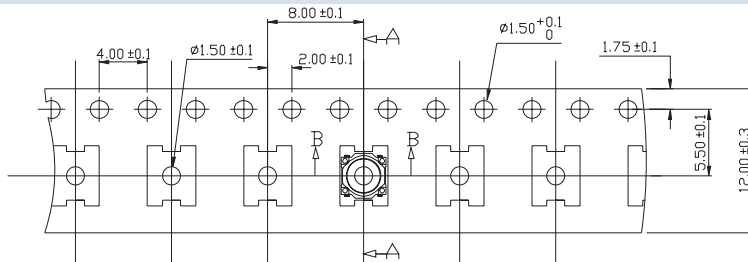

How to order:

TP34 1 2 3

- 1** **TERMINAL TYPE:**
J Bending Type SMT Terminal
- 2** **OPERATING FORCE:**
160 160 ± 50 gf
235 235 ± 50 gf
- 3** **PACKAGING:**
TR Tape & Reel

Note:
> General Tolerance: +/-0.1mm
> Unit in mm and inch (bracketed)

General Specifications:

MECHANICAL

- > Stroke: 0.15±0.1 mm
- > Operating Temperature Range: -20°C to +70 °C
- > Storage Temperature Range: -30°C to +80°C

ELECTRICAL

- > Rating: 50mA 12VDC
- > Contact Resistance: 100mΩ Max.
- > Insulation Resistance: 100MΩ Min. at 100 VDC
- > Dielectric Strength: 100VAC / 1 minute ±5s
- > Contact Arrangement: 1P1T
- > Electrical Life: 500,000 cycles (160gf)
50,000 cycles (235gf)

MATERIALS

- > Halogen-Free Materials
Br < 900 ppm
Cl < 900 ppm
Br+Cl < 1500 ppm
- > Base: UL 94V-0 LCP High Temp Thermoplastic black
- > Contact: Stainless steel with silver cladding
- > Terminal: Phosphor bronze with silver cladding
- > Tape: Kapton